



BRAND PICTURE ALBUM

WWW.SYLGPM.COM

Revised July 2023

沈阳蓝光永磁电机技术有限公司

地址：沈阳市浑南新区世纪路 37 号
邮编：110179

Shenyang Blue Light Permanent Magnet Motor Technology Co., Ltd

TEL: 180 0246 6276

ADD: No.37 Shiji Road, Hunnan New District,
Shenyang, China ZIP: 110179

产品手册

PRODUCT MANUAL

DIRECTORY CONTENT

Product introduction 产品简介

目前油田领域，抽油机设备中主要以塔架式抽油机、游梁式抽油机应用最为广泛，但普遍存在耗能高、效率低、维护困难等问题，我公司依靠三十年专业永磁同步电机技术研发优势，有针对性的先后开发了 BLM 外转子系列曳引型油田电机、BLM 内转子系列曳引型油田电机、BLM 内转子系列超薄型半直驱油田电机等系列产品，实现直驱、半直驱，同时具有节能、可靠性高，故障率低、低速大扭矩等优点，有效提高采油效率，降低能耗、降低维护成本，非常适合油田采油设备的升级换代，同时为使用方带来可观的经济效益。

At present, in the field of oilfields, tower pumping units and beam pumping units are the most widely used in pumping unit equipment, but there are widespread problems such as high energy consumption, low efficiency and difficult maintenance. Our company relies on 30 years of professionalism. Advantages of research and development of permanent magnet synchronous motor technology, targeted development of BLM outer rotor series traction type oil field motor, BLM inner rotor series traction type oil field motor, BLM inner rotor series ultra-thin semi-direct drive oil field motor and other products, It realizes direct drive and semi-direct drive, and has the advantages of energy saving, high reliability, low failure rate, low speed and high torque, effectively improving oil recovery efficiency, reducing energy consumption and reducing maintenance cost. It is very suitable for the upgrading of oilfield oil production equipment. The user brings considerable economic benefits.

NO.1	BLM 内转子系列曳引型油田电机	1-2/P
NO.2	BLM 内转子系列超薄型半直驱油田电机	3-4/P
NO.3	BLM 外转子系列曳引型油田电机	5-6/P
NO.4	各领域产品 & 专利	7-8/P

企业简介 Company profile ENTERPRISE INTRODUCTION

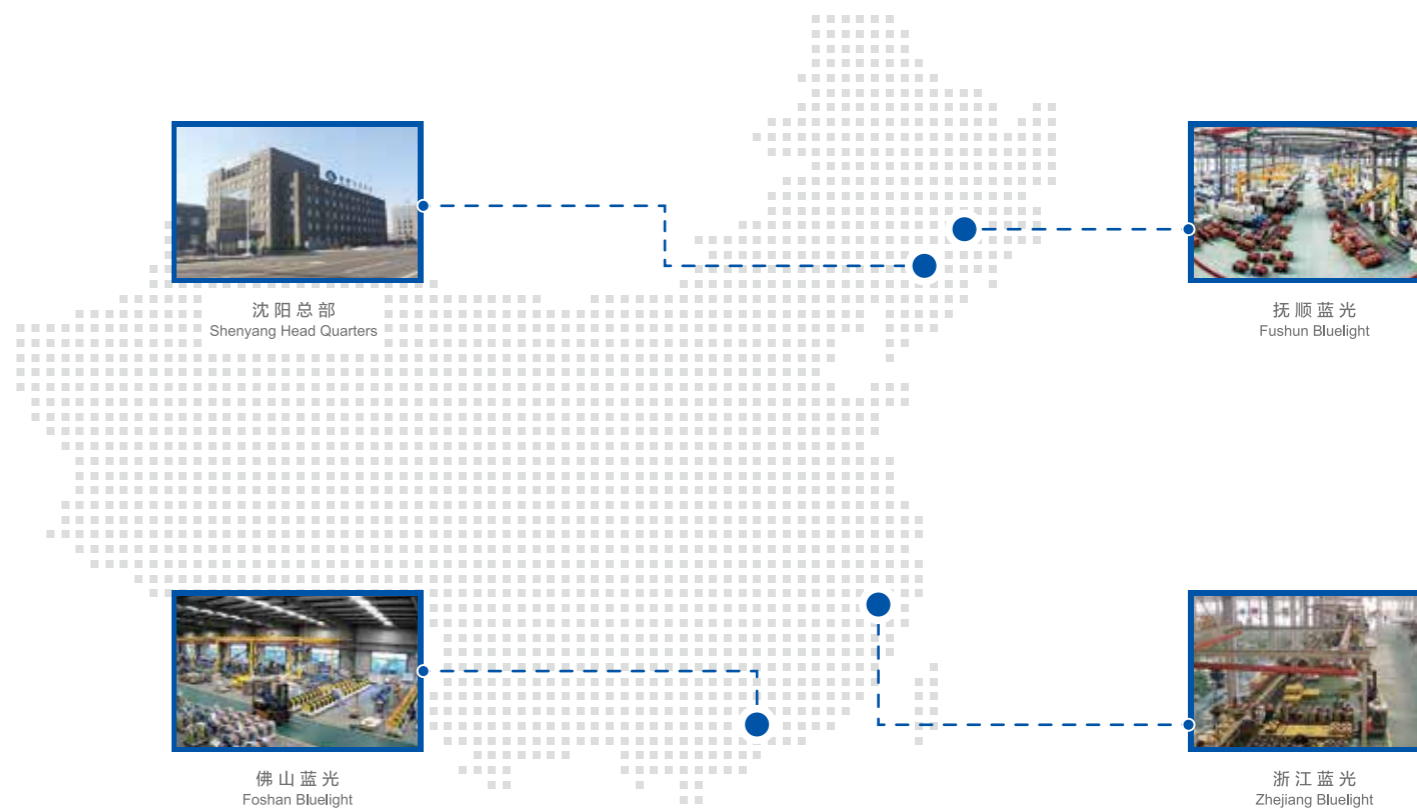

沈阳蓝光永磁电机技术有限公司成立于1989年，是专业研究制造永磁同步电机机系列产品的国家级高新技术企业、市级企业技术中心、ISO9001认证企业，从事永磁电机自主研发生产30年。沈阳蓝光永磁电机技术有限公司总部设在沈阳，在沈阳设有研发、制造基地，在广东佛山及浙江湖州均建有生产基地，具备年产各种用途的永磁同步电机60000台的生产能力，总产能100万千瓦以上。沈阳蓝光永磁电机技术有限公司在永磁电机方面取得近三十项自主知识产权。其中在低速大转矩永磁同步电机直驱技术应用方面持续创新突破，产品输出转矩可覆盖10000牛米以下，提高运行效率，可节能（15%-50%）。沈阳蓝光永磁电机技术有限公司永磁电机产品领域多元化，涉及高精度机床转台、机床直驱电主轴、矿山机戒、油田、天药、食品设备、新能源汽车及自动化注塑等行业。企业承担国家火炬计划项目，国家重点新产品项目，国家创新基金计划项目，市科技计划项目。曾经获得国家第十三届发明展览会银奖、辽宁省科技进步奖科技成果转化奖、沈阳市科技进步奖等荣誉。目前为止，沈阳蓝光永磁电机技术有限公司主要永磁电机产品在全国各地广泛使用，部分产品远销欧洲、美洲、韩国、日本、台湾、中东、东南亚等国家和地区。

Shenyang Blue Light Permanent Magnet Motor Technology Co., Ltd. was established in 1989. It is a national high-tech enterprise, municipal enterprise technology center, and ISO9001 certified enterprise specializing in the research and manufacturing of permanent magnet synchronous motor series products. It has been engaged in independent research and development and production of permanent magnet motors for 30 years. Shenyang Blue Light Permanent Magnet Motor Technology Co., Ltd. is headquartered in Shenyang and has research and development and manufacturing bases in Shenyang. It has production bases in Foshan, Guangdong and Huzhou, Zhejiang, with an annual production capacity of 60000 permanent magnet synchronous motors for various purposes, with a total production capacity of over 1 million kilowatts. Shenyang Blue Light Permanent Magnet Motor Technology Co., Ltd. has obtained nearly 30 independent intellectual property rights in the field of permanent magnet motors. Among them, continuous innovation and breakthroughs have been made in the application of low-speed and high torque permanent magnet synchronous motor direct drive technology. The product can cover an output torque of less than 10000 Nm, improve operating efficiency, and save energy (15% -50%). Shenyang Blue Light Permanent Magnet Motor Technology Co., Ltd. diversifies its permanent magnet motor product field. It involves industries such as high-precision machine tool turntables, machine tool direct drive electric spindles, mining machinery rings, oil fields, Tianyao, food equipment, new energy vehicles, and automated injection molding. Enterprises undertake national torch program projects, national key new product projects, national innovation fund program projects, and municipal science and technology program projects. He has won honors such as the Silver Award at the 13th National Invention Exhibition, the Liaoning Provincial Science and Technology Progress Award for Science and Technology Achievement Transformation, and the Shenyang Science and Technology Progress Award. So far, Shenyang Blue Light Permanent Magnet Motor Technology Co., Ltd.'s main permanent magnet motor products are widely used throughout the country, with some products exported to countries and regions such as Europe, the Americas, South Korea, Japan, Taiwan, the Middle East, and Southeast Asia.

B-TYPE SERISE GENERATOR

BLM

内转子系列曳引型油田电机

BLM inner rotor series traction type oilfield motor

BLM内转子系列曳引型油田电机，主要应用于塔架式抽油机，采用内转子结构，具有较高的防护性能，适合在对密封性要求较高以及更加恶劣的环境中，增加制动器设计，满足客户多样化定制需求，同时为了适应全球市场，额定电压分为380V、480V，最大额定转矩可达7500Nm。

BLM inner rotor series traction type oilfield motor, mainly used in tower type pumping unit, adopts inner rotor structure, has high protection performance, and is suitable for adding brake design in environments with high sealing requirements and more severe environments. To meet the diversified customization needs of customers, and in order to adapt to the global market, the rated voltage is divided into 380V, 480V, and the maximum rated torque can reach 7500Nm.



Features 产品特点

- 采用内转子结构，具有较高的防护性能（IP54），适合应用在对密封性要求较高以及更加恶劣的环境中。
- 对电磁和结构参数进行了精确优化，效率高，动态性能好。
- 搭载了全新的制动系统，采用模块化设计解决客户自行增加制动器，存在的兼容性差、调闸困难、布局浪费等问题，从而达到占地空间小，性价比高的诸多优点。
- 取代抽油机减速机构，直接驱动抽油杆和对重往复运动进行抽油，提高运行效率，减少占地空间。
- 运行平稳、振动小，噪声低、可靠性高。

- The inner rotor structure has high protection performance (IP54), which is suitable for applications with high sealing requirements and harsher environments.
- Accurate optimization of electromagnetic and structural parameters with high efficiency. Accurate optimization of electromagnetic and structural parameters with high efficiency.
- Equipped with a new brake system, the modular design solves the problem of customers adding brakes themselves, such as poor compatibility, difficulty in switching, and waste of layout, thus achieving many advantages such as small footprint and high cost performance.
- Replace the pumping unit speed reduction mechanism, directly drive the sucker rod and pump the counterweight reciprocating motion to improve the operating efficiency, save energy and reduce the floor space.
- Smooth operation, low vibration, low noise and high reliability.

- Product Parameters 产品参数

型号	额定电压V	额定转矩N.m	额定转速rpm	曳引轮直径mm	槽型	槽数	槽宽mm	β角	γ角	钢丝绳直径mm	最大轴负荷T	防护等级	工作制	绝缘等级
BLM-OIT40D460N070A0	380	4000	70	460	U	6	22	80	30	10	20	IP54	S7	F
BLM-OIT45D520N120A0	380	4500	120	520	U	6	22	40	30	10	20	IP54	S7	F
BLM-OIT45D520N120A1	380	4500	120	520	U	6	22	80	30	10	20	IP54	S7	F
BLM-OIT45D520N120A0	480	4500	120	520	U	6	22	40	30	10	20	IP54	S7	F
BLM-OIT45D520N120A1	480	4500	120	520	U	6	22	80	30	10	20	IP54	S7	F
BLM-OIT45D520N070A0	380	4500	70	520	U	6	22	80	30	10	20	IP54	S7	F
BLM-OIT60D520N120A1	380	6000	120	520	U	6	22	80	30	10	20	IP54	S7	F
BLM-OIT75D600N120A0	380	7500	120	600	U	6	22	95	30	13	30	IP54	S7	F
BLM-OIT75D600N120A0	480	7500	120	600	U	6	22	95	30	13	30	IP54	S7	F

- Field Application 现场应用



- Outline Drawing 外形尺寸

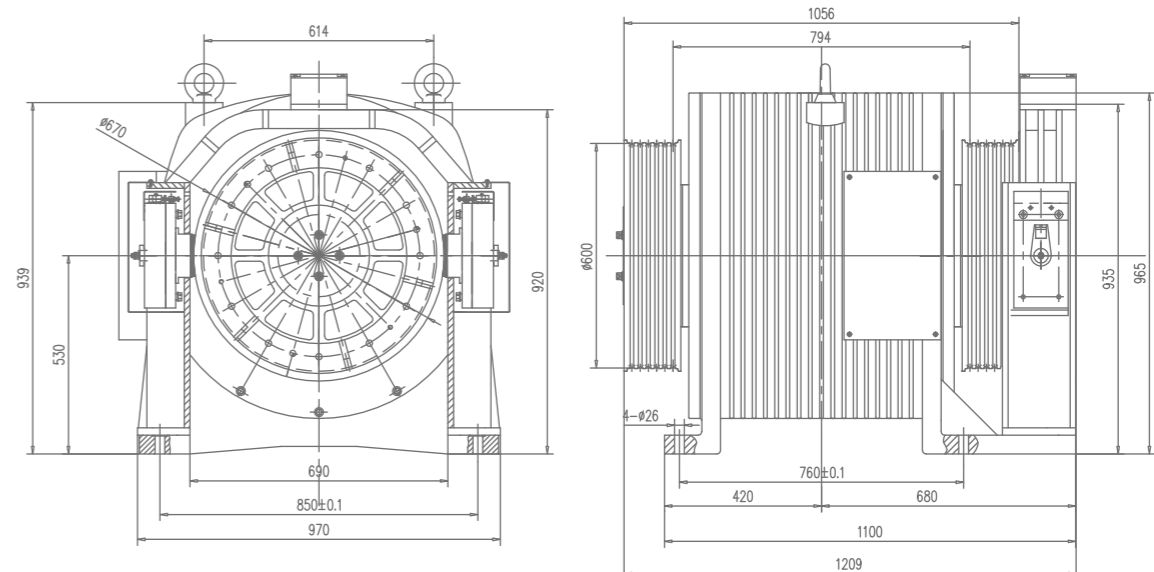

B-TYPE SERISE GENERATOR

BLM

内转子系列超薄型半直驱油田电机

BLM inner rotor series ultra-thin semi-direct drive oilfield motor

BLM内转子系列超薄型半直驱油田电机是我公司专门为游梁式抽油机改造，取消带传动，解决了传统抽油机采用带传动效率低，皮带易磨损影响使用寿命等问题，其直连结构设计合理，布局紧凑，现场改造便捷，节省成本，提高传动效率，减少占地面积，提高电机在室外露天工作的适应性和防水性要求。

BLM inner rotor series ultra-thin semi-direct drive oilfield motor is specially designed for the beam pumping unit of our company. It cancels the belt drive and solves the problems of the traditional pumping unit adopting the belt transmission efficiency and the belt easy to wear and affect the service life. The direct connection structure is reasonable in design, compact in layout, convenient in field modification, cost saving, improved transmission efficiency, reduced floor space, and improved adaptability and waterproofing requirements of the motor in outdoor open air work.



Features 产品特点

- 安装方便、便于改造。
- 模块化集成安装。
- 磁场畸变低，输出转矩平稳，振动小。
- 实现无皮带免维护，安全性高。
- 高效节能，减取消带传动环节，减少传动损耗，实现半直驱。
- 优化电机结构超薄设计，设计空间紧凑，体积小。

- Easy to install and easy to modify.
- Modular integrated installation.
- Low magnetic field distortion, stable output torque and low vibration.
- No belt maintenance-free and high security.
- Efficient and energy-saving, reduce the belt drive link, reduce transmission loss, and achieve semi-direct drive.
- Optimize the ultra-thin design of the motor structure, with compact design space and small size.

- Product Parameters 产品参数

型号	额定电压V	额定电流A	额定转矩N.m	额定功率KW	额定转速rpm	防护等级	工作制	绝缘等级	安装尺寸		
									A	B	C
BLM-OIT13N120	380	31	1337	17	120	IP54	S1	F	4-φ22	110	180
BLM-OIT09N271	380	39	857	24	271	IP54	S1	F	2-φ22	0	120
BLM-OIT18N185	380	56	1766	34	185	IP54	S1	F	4-φ22	150	250
BLM-OIT14N255	380	86	1385	37	255	IP54	S1	F	4-φ22	110	180
BLM-OIT17N255	380	105	1685	45	255	IP54	S1	F	4-φ22	130	190
BLM-OIT21N255	380	128	2059	55	255	IP54	S1	F	4-φ22	130	200
BLM-OIT28N255	380	175	2808	75	255	IP54	S1	F	4-φ22	170	230

- Field Application 现场应用



改造前 Before



改造后 After

- Outline Drawing 外形尺寸

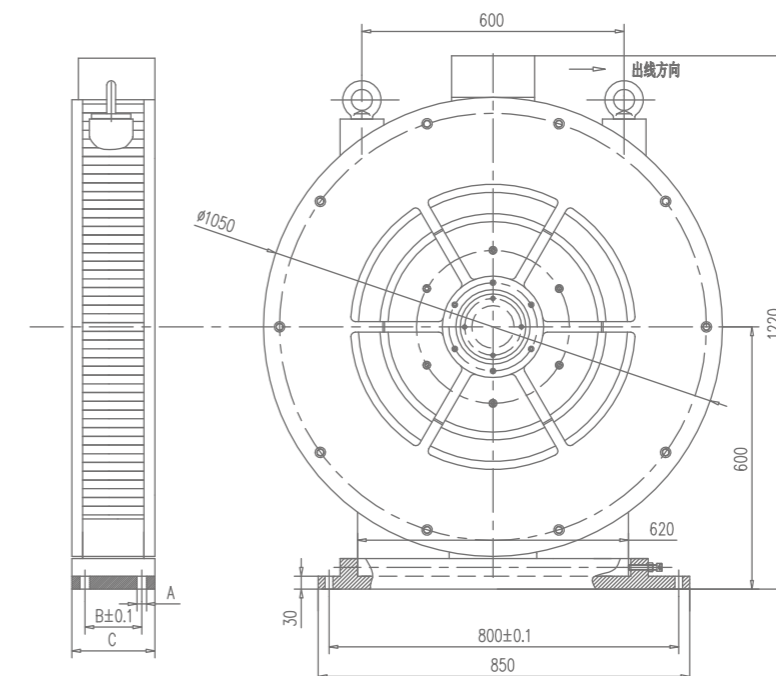

B-TYPE SERISE GENERATOR

BLM

外转子系列曳引型油田电机

BLM outer rotor series traction type oilfield motor

BLM外转子系列曳引型油田电机，主要应用于塔架式抽油机，取消复杂的减速机构，降低维护成本，实现直驱，提高效率，采用外转子结构，结构紧凑，减少占地空间，最大限度的提高了输出转矩，目前我公司标准产品覆盖在额定转矩3000Nm~6000Nm之间。

BLM outer rotor series traction type oilfield motor, mainly used in tower type pumping unit, eliminating complicated speed reduction mechanism, reducing maintenance cost, realizing direct drive, improving efficiency, adopting outer rotor structure, compact structure and reducing floor space. The output torque is maximized. At present, our company's standard products cover the rated torque between 3000Nm and 6000Nm.

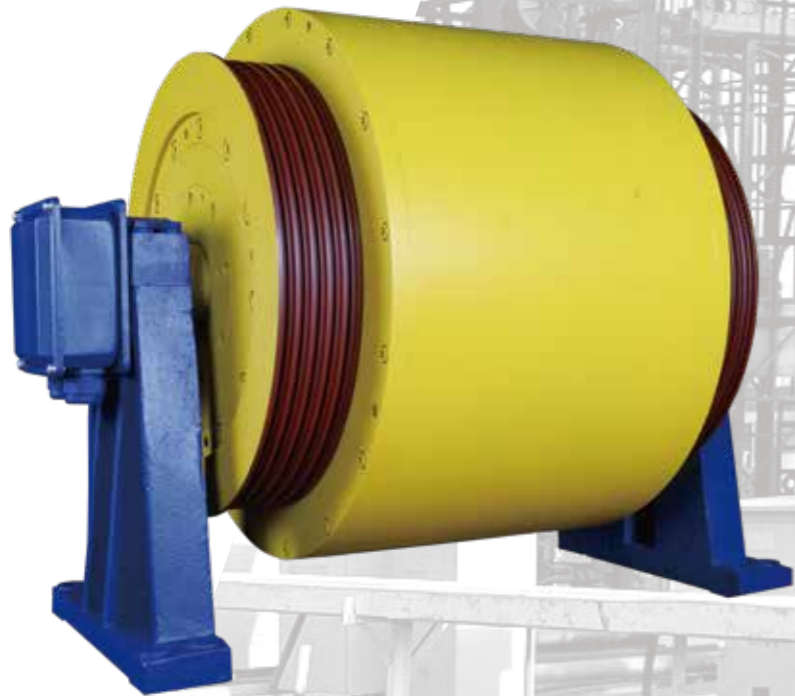

Features 产品特点

- 优化散热结构，散热好、温升低。
- 轻量化设计，在调速过程中速度响应快可获得较高的加速度，动态性能好。
- 采用外转子双支撑结构，最大的轴负荷可以达到20000kg。
- 取代抽油机减速机构，直接驱动抽油杆和对重往复运动进行抽油，提高运行效率，减少占地空间。
- 适用于高耗能、低速、重载、大扭矩油田领域。

- Optimize the heat dissipation structure, good heat dissipation and low temperature rise.
- Lightweight design, high speed response during high speed control, high dynamic performance.
- Using the outer rotor double support structure, the maximum axle load can reach 20,000kg.
- Replace the pumping unit speed reduction mechanism, directly drive the sucker rod and pump the counterweight reciprocating motion to improve the operating efficiency, save energy and reduce the floor space.
- Suitable for high energy, low speed, heavy load, high torque oil fields.

- Product Parameters 产品参数

型号	额定电压V	额定转矩N.m	额定转速rpm	曳引轮直径mm	槽型	槽数	槽宽mm	β角	γ角	钢丝绳直径mm	最大轴负荷T	防护等级	工作制	绝缘等级	安装尺寸			
															A	B	C	D
BLM-OT30D550N050A0	380	3000	50	550	U	4	19	60	30	12	20	IP41	S7	F	429	667	787	835
BLM-OT30D600N048A0	380	3000	48	600	U	4	24	40	30	13	20	IP41	S7	F	414	667	787	835
BLM-OT35D600N047A0	380	3500	46.5	600	U	5	20	80	35	13	20	IP41	S7	F	530	831	951	999
BLM-OT45D520N047A0	380	4500	46.5	520	U	5	20	60	30	13	20	IP41	S7	F	530	831	951	999
BLM-OT45D600N047A0	380	4500	46.5	600	U	5	20	40	30	13	20	IP41	S7	F	530	831	951	999
BLM-OT45D600N047A1					U	5	20	80	35	13	20	IP41	S7	F				
BLM-OT45D600N047A2					U	5	20	95	35	13	20	IP41	S7	F				
BLM-OT60D525N048A0	380	6000	48	525	U	5	20	40	30	13	20	IP41	S7	F	630	931	1051	1119

- Outline Drawing 外形尺寸

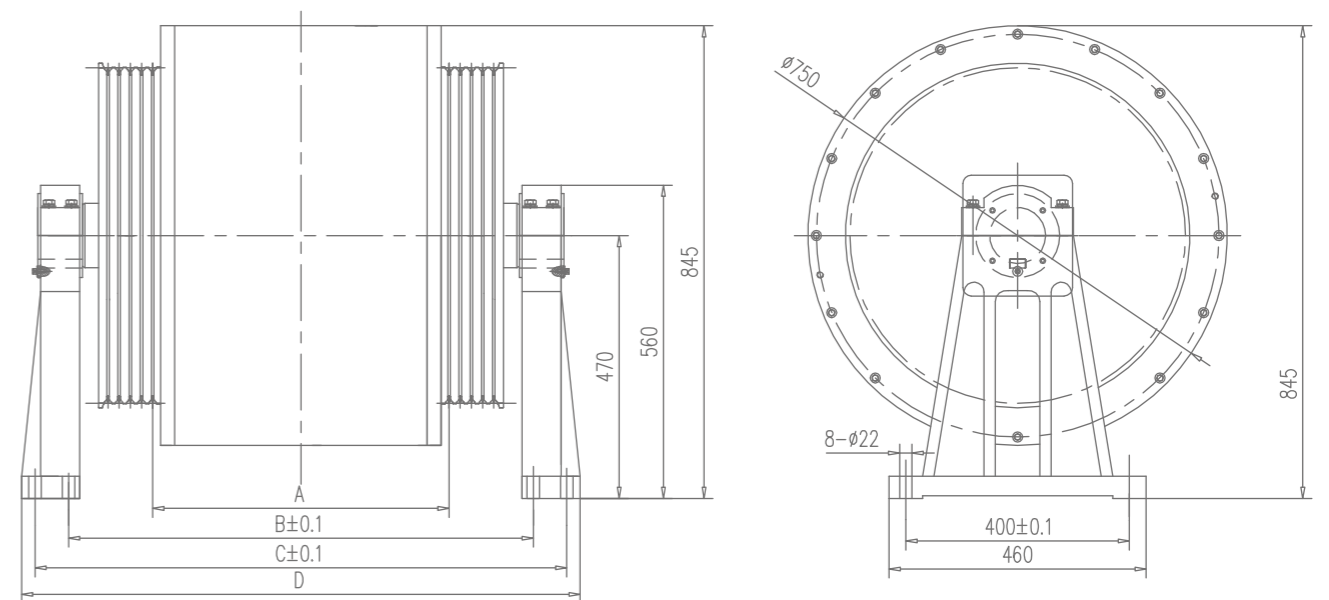

Machine Type Recommendation 蓝光各领域产品

沈阳蓝光永磁电机产品涵盖多个领域，包括高精度机床、矿山机械、油田、医药、食品设备，新能源汽车及自动化注塑等行业。



油田用外转子
永磁同步电机



制药设备、食品加工
设备用低速大转矩垂直
搅拌永磁电机



BLI系列快速响应
低惯量交流伺服电机

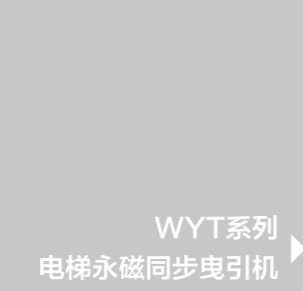

WYT系列
电梯永磁同步曳引机



高效重载冷却塔
直驱永磁同步电机



油田用超薄型内转
子永磁同步电机



注塑机同步熔胶，挤出机、
混料机用 BLI-A 系列低速
大转矩永磁直驱电机



沈阳蓝光是研究制造永磁电机国家级高新技术企业，省级企业技术中心，可根据客户的需求，提供有针对性的专属产品与解决方案。



“ 沈阳蓝光拥有一支专业的研发团队，把拥有自主知识产权和独立的核心技术视为企业的立足点和持续发展的原动力，也是为国内外用户提供优质、可靠产品的有效保证 ”

